

CONTURA

Specifications



Universal 3D-CMM
with measuring probe heads

- Economic
- Versatile
- User-oriented
- Accurate



We make it visible!

Description

- CNC-controlled measuring machines with measuring probe heads
- Crossbeam and quill are made of ceramic material which is virtually insensitive to temperature fluctuations, humidity and contamination.
- Takes up amazingly little space by integrating the controller into the machine base.
- Several sizes for optimal measuring volume

Application

- For use in your production environment and tool shop, in the receiving department and final inspection.
- For large and small parts, whether they are made of metal or plastic.
- For production screening or individual workpiece inspection.
- For pallet measurement also of different parts in several, unmanned shifts.

Technical Features

- Bridge-type CMM with stationary machine table and lateral bridge drive → for acceleration-free measurement and constant precision within the entire measuring volume
- Cross beam and quill made of ceramic material → for insensitive factory use
- Air bearings on all four sides of the Y-guideway → for additional rigidity and stability
- Capstan drives → for high acceleration and speed in the CNC mode
- Computer-aided compensation of mechanical residual errors (CAA) → for lasting, consistent accuracy
- Ergonomic operator panel → for optimal static and dynamic construction
- Passive vibration damping system

Select Equipment

When conditions become worse or the accuracy has to be better:

- Increased accuracy
- Extended temperature conditions
- Temperature sensor for workpiece, machine temperature sensor

Sensor Technology

Zeiss VAST_{XT} universal probe

- VAST: Variable Accuracy and Speed Probing Technology
- For scanning multi-point and single point measurements
- Just the right one, if statements are required not only on dimension and position but also on form
- Just the right one, if function-oriented inspection is required with ring or plug gage
- Just the right one, if the probing technology is to be adapted to the measuring task - and not vice versa.

Zeiss probe DT

- Measuring single-point probe system
- Adjustable measuring force
- Dynamic single-point probing for more probing security
- Upgradeable to scanning probe VAST_{XT} under usage of the same styli configurations and probe change rack; assembly on site.

A reliable, long-term return on your investment – with CONTURA

- Additional CONTURA performance characteristics:
 - Probe changing magazine (option)

Control

- Ergonomic control panel, switchable to creep speed → for manual control of CMM with joysticks with progressive characteristics
- with two joysticks → for exact driving in three axes
- and variable speed control → for the measuring speed to be reduced, e.g. when performing CNC runs for checking the collision hazard and error-free operation

Software

The Zeiss measuring library

- links up all areas of product creation: development, design, construction, testing, production, quality control ...
- uses the same data base in all areas
- provides a solution for any measuring application
- is based on modern hardware platforms under MS Windows, Linux and UNIX
- operates interactively with CAD
- has networking, multi-user and multi-tasking capabilities

- supports process-oriented production
- generates complex measuring runs automatically
- makes your processes reliable due to statistics functions and data feedback to your production department

And last but not least:

- The Zeiss measuring software guides you through your metrology work with user-friendly menu prompting and programming logic.

Dimensions and Weights		7/7/6	7/10/6	10/12/6	10/16/6
Measuring range	X in mm (in.)	700 (27.5)	700 (27.5)	1000 (39.4)	1000 (39.4)
	Y in mm (in.)	700 (27.5)	1000 (39.4)	1200 (47.2)	1600 (63.0)
	Z in mm (in.)	600 (23.6)	600 (23.6)	600 (23.6)	600 (23.6)
Overall CMM dimensions	width in mm (in.)	1560 (61.5)	1560 (61.5)	1865 (73.3)	1865 (73.3)
	length in mm (in.)	1535 (60.5)	1840 (72.5)	2040 (80.3)	2440 (96.1)
	height in mm (in.)	2800 (110.5)	2800 (110.5)	2800 (110.5)	2800 (110.5)
Table height	mm (in.)	850 (33.4)	850 (33.4)	850 (33.4)	850 (33.4)
Clearance under bridge	mm (in.)	850 (33.4)	850 (33.4)	850 (33.4)	850 (33.4)
Clearance under probe head	mm (in.)	680 (26.7)	680 (26.7)	680 (26.7)	680 (26.7)
Work table area X, Y	mm (in.)	920 x 1016 (36.2 x 40)	920 x 1340 (36.2 x 52.7)	1225 x 1540 (48.2 x 60.6)	1225 x 1940 (48.2 x 76.4)
CMM weight	kg (lb)	1270 (2800)	1640 (3615)	2530 (5580)	2950 (6500)
Maximum workpiece weight	kg (lb)	560 (1230)	730 (1606)	1150 (2530)	1500 (3300)

Accuracy Data ¹⁾		X = 700 mm (27.5 in.)		X = 1000 mm (39.4 in.)	
		CONTURA	CONTURA Select	CONTURA	CONTURA Select
Length (size) measuring error ²⁾ MPE acc. EN ISO 10360-2	for E in µm (in./1000)	2.5+L/250 (0.089+L/250)	2.0+L/300 at 18 - 22 °C (0.079+L/300 at 64 - 72 °F) 2.3+L/300 at 18 - 26 °C (0.091+L/300 at 64 - 79 °F)	2.7+L/250 (0.106+L/250)	2.2+L/300 at 18 - 22 °C (0.087+L/300 at 64 - 72 °F) 2.5+L/300 at 18 - 26 °C (0.098+L/300 at 64 - 79 °F)
	Probing error MPE acc. EN ISO 10360-2 per VDI/VDE 2617 ³⁾ (probing uncertainty) V ₂ in µm (in./1000)	for P in µm (in./1000)	2.4 (0.094) 2.0 (0.079)	2.0 (0.079) 1.7 (0.067)	2.4 (0.094) 2.2 (0.087)
Scanning probing error ³⁾ MPE per EN ISO 10360-4 required measuring time	for THP in µm (in./1000)	4.6 (0.181)	4.1 (0.161)	4.8 (0.189)	4.3 (0.169)
	τ in sec.	72	72	72	72
Form measurement error ³⁾ MPE for roundness acc. EN ISO 12181 ⁴⁾	RONt (MZCI) in µm (in./1000)	4.0 (0.158)	3.4 (0.134)	4.4 (0.173)	3.8 (0.149)
	Scales Resolution	Zeiss glass scales; reflected light system, photoelectric 0.2 µm (0.000 008 in.)			

1) Stylus for acceptance test: Length 60 mm (2.4 in.), stylus tip diameter 8 mm (0.32 in.)

2) L = measured length in mm (in.).

3) For VAST_{XT} only

4) Used filter 50 W/U, scanning speed at V₂ and roundness: 5 mm/s (0.2 ips)

Dynamics				
Travel speeds		axial		vectorial
		Set-up:	0 to 70 mm/s (0 to 2.8 ips)	
Measuring operation:		max. 250 mm/s (10 ips)	max. 425 mm/s (17 ips)	
Creep speed:	0 to 5 mm/s (0 to 0.2 ips)			
Acceleration:		max. 1000 mm/s ² (39 ips ²)	max. 1700 mm/s ² (67 ips ²)	

Probe Systems	
Probe systems	Zeiss VAST_{XT} universal probe for scanning and single point measurements; Zeiss DT for single point measurements. Full collision protection of mobile part up to v=70 mm/s (2.8 ips)
Measuring force during data acquisition:	Variable, 50 to 1000 mN
Styli weight:	Maximum 500 g (17.6 oz.) (incl. adapter plate)
Probe length:	Maximum 500 mm (19.7 in.)
Styli tip diameter:	Minimum 1 mm (0.04 in.)
Probe changing system	Manual change by push-button control at panel (electromagnetic clamping) Optional: CNC change in connection with probe magazine or ProMax active probe magazine (without loss in measuring range)

Supply Data	
Power supply	1/N/PE 100/110/115/120/125/230/240 V (±10%); 50-60 Hz (±3.5%) Max. power consumption: 1000 VA
Air supply	Supply pressure 6 to 8 bar (87 to 116 psi), pre-filtered, Approx. consumption at 5.0 bar (72 psi) 30 l/min (1.05 cfm), Air quality according to ISO 8573 part 1, classification 4

Ambient Requirements			
Air humidity	40% to 60%		
Permissible ambient temperature	+17°C to +35°C (63 °F to 95 °F)		
Temperature ranges in which the specified maximum permissible errors are guaranteed	Ambient temperature	CONTURA 18 - 22 °C (65 °F - 72 °F)	CONTURA Select 18 - 26 °C (65 °F - 79 °F)
	Thermal fluctuations per hour	1.0 K/h (1.8 °F/h)	2.0 (3.6 °F/h)
	per day	1.5 K/h (2.7 °F/h)	3.0 K/h (6.0 °F/h)
	Thermal gradient spacial	1.0 K/m (0.5 °F/ft)	1.0 K/m (0.5 °F/ft)

CONTURA

Dimensions in mm (in.)

CONTURA	7/7/6	7/10/6	10/12/6	10/16/6
b	1535 (60.4)	1840 (72.4)	2040 (80.3)	2440 (96.1)
c	920 (36.2)	920 (36.2)	1225 (48.2)	1225 (48.2)
d	1560 (61.3)	1560 (61.3)	1865 (73.3)	1865 (73.3)

CONTURA CMMs fulfill the EC machinery-directive 98/37/EC including the low voltage-directive 73/23/ECC and the EMC directive 89/336/ECC.

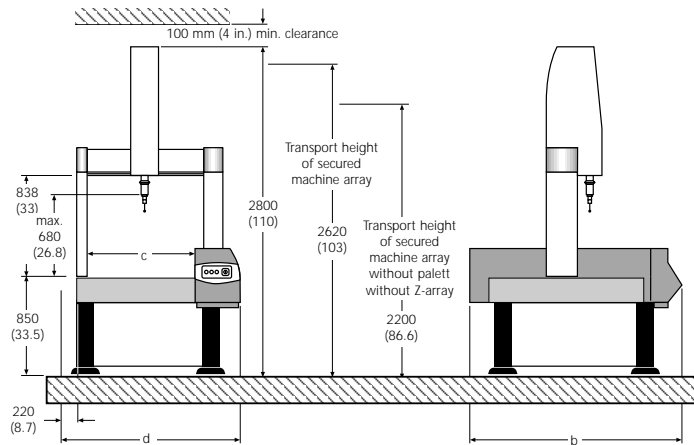

Explanations to CONTURA accuracy

MPE = Maximum Permissible Error

As defined in the DIN EN ISO 10360, every specification for accuracy will be noted with "Maximum Permissible error (MPE)". MPE defines a maximum value that a measuring deviation is not allowed to exceed. Accuracy results are represented as an index number. MPE_E describes the length measuring error and MPE_P describes the probing error.

Maximum Permissible Error for length measurement

MPE_E

To determine length measuring error, calibrated gage blocks or step gage blocks are measured. With every measurement, 5 different lengths in 7 different positions within the measuring range of the CMM will be determined according to ISO 10360-2.

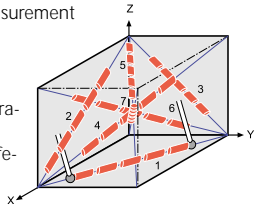

Every length will be measured 3 times. None of the 105 measurements are allowed to deviate from the calibrated value by more than the specified amount. The specification is in most cases dependent on the length, written in the form $MPE_E = A + L/K$, whereby L represents the length. Sometimes the formula will be written as $MPE_E = A + F \cdot L/K$, in which case the formula must be converted in order to compare it to the first variation. For example, the values $MPE_E = 2.5 + 1.5 \cdot L/333$ and $MPE_E = 2.5 + L/220$ are the same.

Maximum Permissible Error for probing

MPE_P

To determine the probing error, a sphere (diameter 10 to 50 mm) with negligible form error will be probed on 25 recommended positions (from ISO 10360-2). From the measurement results, a so called Gaussian least squares sphere is calculated. The range of radial distances from the associated is not allowed to exceed the specification.

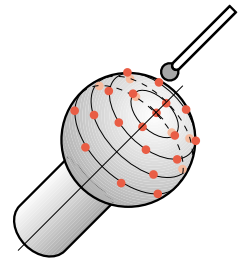

Maximum Permissible Error for form measurement (roundness)

$MPE_{RONT}(MZCI)$

The application of CMMs for form measurement is discussed in VDI 2617, sheet 2.2. Parameters for roundness measurements are defined in DIN EN ISO 12181.

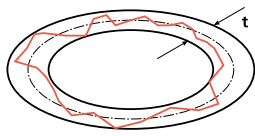

For testing, a 50 mm ring gage with negligible form error is measured with high point density (with Zeiss: scanning mode). From the measurement results, a so called Tschebyscheff-circle (MZCI = minimum zone circle) is calculated. The outcome of the form deviation results in the range of radial distances of this circle. It is not allowed to exceed the specification.

Maximum Permissible Error for scanning probing

MPE_{THP} and MPE_{τ}

To determine the scanning probing error, a sphere (diameter of 25 mm) with negligible form error will be scanned along 4 recommended scanning lines (from ISO 10360-4). When comparing the measurements with the MPE_{THP} specifications, there are two conditions that must be met. First, the range that is determined from radial distances from the associated sphere is not allowed to exceed the specification (see MPE_P). Second, the deviation between the radial distances and the calibrated sphere diameter is not allowed to exceed the specification. Additionally, the time required (τ) for the test must be specified, as speed has an enormous influence on the results.

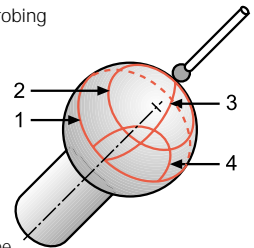

When the accuracy and time needed is indicated, the specification of the scanning probing error is an important indicator of the productivity of a CMM.

Carl Zeiss
Industrial Metrology
73446 Oberkochen/Germany
Sales: +49 18 03 33 63 36
Service: +49 18 03 33 63 37
Fax: +49 73 64 20 38 70
E-mail: imt@zeiss.de
Internet: www.zeiss.de/imt

Carl Zeiss
IMT Corporation
6250 Sycamore Lane N.E.
Minneapolis, MN 55369
Phone: +1 763 533-9990
Fax: +1 763 533-0219
E-Mail: imt@zeiss.com
Internet: www.zeiss.com/imt